

GPS Receiver System

SOKKIA

RADIAN™ IS

Advanced Reference Materials
Cable Pinout Specifications

Part Number 750-0-0082 Rev 1

Copyright Notice

© 2001 Point, Inc. All rights reserved.

No part of this publication or the equipment described in it may be reproduced, translated, stored in a retrieval system, or transmitted in any form or by any means, electronic, mechanical photocopying, recording, or otherwise, without prior written permission of Point, Inc. Your rights with regard to this publication and the equipment are subject to the restrictions and limitations imposed by the copyright laws of the United States of America ("U.S.A.") and/or the jurisdiction in which you are located.

Trademark Notice

Sokkia is a trademark of Sokkia Co. Ltd. Spectrum, SDR and Electronic Field Book are registered trademarks of Point, Inc. Radian IS is a trademark of Point, Inc. All other product and brand names are trademarks or registered trademarks of their respective holders.

FCC Notice

The equipment described in this manual has been tested pursuant to Part 15 of the FCC Rules and found to comply with the limits for a Class A digital device for use in commercial business, and industrial environments. Operation is subject to the following two conditions: (1) this device may not cause harmful interference, and (2) this device must accept any interference received, including interference that may cause undesired operation. These limits are designed to provide reasonable protection against harmful interference when the equipment is operated in a commercial environment. The equipment generates, uses, and can radiate radio frequency energy and, if not installed and used in accordance with the instruction manual, may cause harmful interference to radio and television reception. Operation of this equipment in a residential area is likely to cause harmful interference in which case the user will be required to correct the interference at his own expense.

If this equipment does cause interference to radio or television reception, which can be determined by turning the equipment off and on, you can try to correct the interference by one or more of the following measures:

- Reorient the receiving antenna.
- Relocate the receiver relative to the equipment which it interferes.
- Power the equipment from a different AC receptacle so that this equipment and the interfered equipment are on different branch circuits. If necessary, contact our customer service department or an authorized representative for additional advice.

CE Notice

Warning: This is a Class A product. In domestic environments this product may cause radio interference in which case the user may be required to take adequate measures.

Printed on recycled paper.

Part# 750-0-0082 Rev 1

01-00001-02

Contents

Section 1	Introduction	1
Section 2	Radian IS Ports and Cables	2
2.1	Introduction	2
2.1.1	Power Port Overview	4
2.1.2	Power Cable Overview	5
2.1.3	Communication Ports Overview	6
2.1.4	Communication Cables Overview	7
Section 3	Power	9
3.1	Power Port.....	9
3.2	SLA Power Cable (403-0-0088)	10
3.3	General-Purpose Power Cable (403-0-0065).....	11
3.4	Radian IS to SAE Power Cable (403-0-0076)	12
Section 4	Serial Communications	13
4.1	Communication Ports.....	13
4.2	Radio Data Cable (403-0-0037)	14
4.3	PC Data Cable (403-0-0036)	15
4.4	SDR33 Data/Power Cable (403-0-0035).....	16
4.5	GPS Receiver/DAP Cable (403-0-0061 coiled; 403-0-0082 straight)17	
4.6	Rover PDL Radio Cable (403-0-0069; 403-0-0091 and 403-0-0043 variations)18	
4.7	Base PDL Radio Cable (403-0-0062).....	20
Index	21

Figures

1	Ports	3
2	Power Port Close-Up	9
3	SLA Power Cable - Illustration	10
4	SAE to Battery Spring Clips Power Cable Section - Illustration	11
5	Radian to SAE Power Cable Section - Illustration	12
6	COM Port Close-Up	13
7	Radio Data Cable - Illustration	14
8	PC Data Cable - Illustration	15
9	SDR33 Data/Power Cable - Illustration	16
10	GPS Receiver/DAP Straight Cable - Illustration	17
11	Radian IS Radio/Rover Straight Cable - (403-0-0069) Illustration	18
12	Radian IS Radio/Rover Right Angle Cable - (403-0-0043) Illustration	19
13	Radian IS Radio/Base/SAE Cable - Illustration	20

Tables

1	SLA Power Cable - Pin Configuration	10
2	General-Purpose Power Cable - Spring Clip Configuration	11
3	General Purpose Power Cable - SAE Configuration	11
4	Radian to SAE Power Cable - Lemo Pin Configuration ...	12
5	Radian to SAE Power Cable - SAE Configuration	12
6	Radio Data Cable - Pin Assignment	14
7	PC Data Cable - Pin Assignment	15
8	SDR33 Data/Power Cable - Pin Configuration	16
9	GPS Receiver/DAP Straight /Coiled Cable - Pin Configuration	17
10	Radian IS Radio/Rover - Pin Configuration	19
11	Radian IS Radio/Base/SAE - Pin Configuration	20

Section 1 Introduction

Welcome to the *Radian IS Advanced Reference Materials*. This information is intended for advanced users only.

This document provides information on the cables and cable pinouts that work with the Radian IS receiver system.

Use the cable information if you plan to create cables to use with your Radian IS system.

Note that ready-made cables, tested with the Radian IS system, are available through your Sokkia dealer.

Sokkia cannot guarantee your data results if you use home-made cables, or cables not tested by Sokkia, with your Radian IS.

For more information on the Radian IS, please refer to the *Radian IS Operations Manual*, part number 750-1-0069.

Section 2

Radian IS Ports and Cables

The following sections provide information about the ports on the Radian IS and the cables that work with the system. When possible, illustrations of the cables, pinout configurations and ports are provided.

This information is intended for use by advanced users who want to create cables to work with the system. It should be noted that when you purchase the Radian IS system, you will be provided with all the necessary cables to run your system. It is not necessary to create your own cables.

2.1 Introduction

The Radian IS features an external power port and two communication ports. All ports are located on the side of the enclosure and are protected by covers that should not be open unless the port is in use. The port covers are permanently attached to the Radian IS enclosure.

The Radian IS ports enable the following:

Power enables you to power your Radian IS using an external power source, such as a car battery. This is an alternative to using the Radian IS internal batteries.

Communications..... enables you to communicate with accessory devices, such as the data collector or the radio. As well, each communication port provides a power output for powering certain models of these accessory devices.

The ports are labeled with icons and text for easy identification:

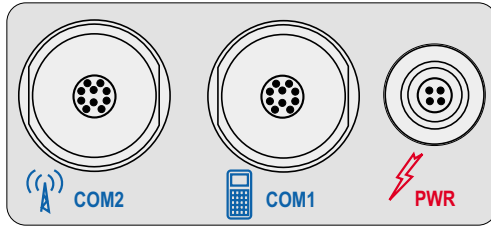

Figure 1: Ports

-
- ☒ **Notes:** The Radian IS power port (female) is different from, although similar to, the Radian power port (male).

The communication (COM) ports on the Radian IS are the same as those on the Radian and NovAtel DL.

Each connector is keyed to ensure that the cable can be inserted in only one way. The connectors that are used have a latching mechanism that cannot be opened by pulling on the cable. Observe the following when handling the cables.

- To insert a cable, make certain you are using the appropriate cable for the port (For example, the power cable has a different connector than the communications cable).
- Line up the red dot on the cable connector with the red index mark on the port on the Radian IS.
- Insert the cable connector until it seats with a click; it is now locked in place.
- To remove a cable, grasp its connector by the knurled ring and pull. **DO NOT PULL DIRECTLY ON THE CABLE.**

2.1.1 Power Port Overview

The Radian IS requires power input to operate. You may decide to power the Radian IS using its internal batteries (refer to your *Radian IS Operations Manual* for more information), or you can choose to attach an external power source to the system. External power can come from a 12V battery, a wall outlet adapter (AC/DC converter), or an automotive power source (car cigarette adapter). These options are available from your local Sokkia dealer.

The Radian IS has an internal power module that does the following:

- filters and regulates the supply voltage
- protects against over-voltage, over-current, and high-temperature conditions
- provides automatic reset circuit protection

WARNING

Do not supply the Radian IS with an input voltage that is outside the allowable range. Refer to your *Radian IS Operations Manual* for more information.

The Radian IS can be powered from a 12V battery. Once the battery is depleted, the Radian IS shuts off. To maximize a battery's lifetime, the Radian IS does not use the battery once it is discharged despite any contrary effects present. If any external power source fails, the Radian IS will shut off to avoid loss of data.

☒ **Note:** The Radian IS data collection mechanism is designed to be robust and to endure power interruptions (and similar disruptive events) with minimum loss of data. In these situations, less than five minutes of data (prior to the disruptive event) are lost. To an extent, error messages attempt to describe the problem.

Further information on power can be obtained from the following locations:

- For pin-out information on the 4-pin power connector, see *Section 3, Power*.
- For a listing of the required input supply voltages, and the typical power consumption in ON and OFF modes, refer to the *Power Requirements* section of your *Radian IS Operations Manual*.

For a listing of the voltage levels at which the Radian IS switches from one source to another, or at which the Radian IS shuts off, refer to your *Radian IS Operations Manual*.

2.1.2 Power Cable Overview

Several power cables are available for use with the Radian IS. These cables enable you to power the Radian IS by a DC source.

- SLA (403-0-0088)**..... 0.75 m (2.46 ft) length, 4-pin LEMO to 4-pin LEMO for connecting to the Sokkia sealed lead acid (SLA) battery; it is described further in Section 3.2, *SLA Power Cable*, Page 9.
- General-Purpose (403-0-0065)** SAE to two battery spring-clips for use with 403-0-0076; it is described further in Section 3.6, *General-Purpose Power Cable*, Page 13.
- SAE (403-0-0076)**..... Radian IS to SAE cable for use with PDL base battery and other power cables that have an SAE connector; it is described further in Section 3.4, *Radian IS to SAE Power Cable (403-0-0076)*, Page 12.

2.1.3 Communication Ports Overview

The two Radian IS communication ports (COM1 and COM2) are bi-directional.

COM1 is intended for use with the SDR, and COM2 is intended for use with a radio/modem in RTK applications. The communication ports (or COM ports) feature the following:

- 4800, 9600, 19200, 38400, 57600 and 115200 baud
- RS-232 (EIA/TIA-232-E) signal levels
- Electromagnetic interference suppression filters
- Hardware and software flow control operation
- Output power for peripheral devices (For example, SDR, low-power radio transceiver)
 - The output voltage from the com port is the same as the input to the unit. If the internal batteries of the Radian IS are used, the output is 7.2V nominal. If an external power source is used, such as the external 12V battery pack, then the port will also output 12V.
 - The total combined current for both ports should not exceed 1A.
 - The ripple voltage is the same as the power source. If used with batteries, the ripple will be negligible. If an external AC to DC converter is used, the ripple on the COM port power will be the same as the converter's.

For communication to occur, the Radian IS COM port configuration must match that of the external device's. The Radian IS's default port settings are:

```
RS232C, 9600 BPS, no parity, 8 data bits, 1 stop  
bit, no handshaking, echo off
```

When using the SDR, the Radian IS baud rates will be automatically set by the SDR to 19200 (refer to your *SDR Reference Manual*).

2.1.4 Communication Cables Overview

Various communication cables are available to connect the Radian IS to a PC, radio/modem, controller, or other devices. They are described as follows:

- PC (403-0-0036)** 10-pin LEMO plug to 9-pin D-connector (DE9S socket); it is described further in Section 4.3, *PC Data Cable*, Page 17.
- SDR33 (403-0-0035)** 10-pin LEMO plug to 6-pin Fischer connector with a coiled cable; it is described further in Section 4.4, *SDR Data/Power Cable*, Page 18.
- DAP** 10-pin LEMO to 7-pin LEMO with either a straight or coiled cable; they are further described in Section 4.5, *GPS Receiver/DAP Cable*, Page 18.
- **403-0-0082** - Straight cable
 - **403-0-0061** - Coiled cable
- Base PDL Radio (403-0-0062)** 10-pin LEMO and SAE connector to 6-pin Fischer connector; it is further described in Section 4.7, *SAE and Radian IS Radio/Base Cable*, Page 21.
- Rover PDL Radio** 10-pin LEMO plug to 5-pin LEMO connector in 3 variations that are further described in Section 4.6, *Radian IS Radio/Rover Cable*, Page 19:
- **403-0-0069** - 23 inches long with straight ends
 - **403-0-0091** - 23 inches long with right angled ends
 - **403-0-0043** - 60 inches long with one straight and one right angled end

Other Radio..... 10-pin LEMO plug to 9-pin
(403-0-0037) D-connector(DE9P plug); it is
described further in Section 4.2, *Radio
Data Cable*, Page 16.

The 10-pin plug on each cable can be plugged into either the COM1 or COM2 port on the Radian IS.

For further information on the signals or connector pin-outs for the communication ports or cables, see Section 4, **Serial Communications**.

Section 3 Power

The following subsections provide technical information about the Radian IS power port and power cable pinouts.

The information in the following subsections will guide you in creating power cables to externally power your Radian IS system.

Although the Radian IS can be powered using an external power source, the Radian IS is equipped with two internal battery compartments for internally powering your system. Please refer to your *Radian IS Operations Manual* for more information.

As well, ready-made and tested cables are provided by Sokkia for use with your system. Please contact your Sokkia dealer for more information.

For an overview of the power port and cables, see Section 2, **Radian IS Ports and Cables**.

3.1 Power Port

The power port on the Radian IS is a LEMO HGM.0B.304.

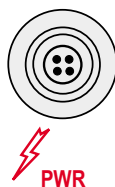

Figure 2: Power Port Close-Up

Mating connectors may be made by LEMO, ODU and Fischer.

3.2 SLA Power Cable (403-0-0088)

The SLA power cable is 0.75 meters (29.5 inches) and has 4-pin LEMO to 4-pin LEMO connector ends.

Use the power cable to connect your SLA battery to the PWR port on your Radian IS receiver.

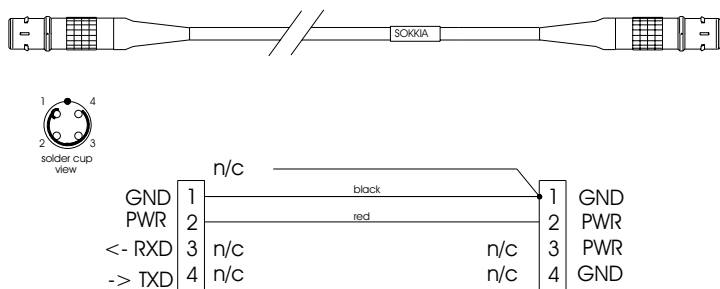

Figure 3: SLA Power Cable - Illustration

Table 1: SLA Power Cable - Pin Configuration

LEMO Pin	Description	Color	LEMO Pin	Description
1	Ground	Red	1	Ground
2	Battery A	Black	2	Battery A
3	no connection	-	3	no connection
4	no connection	-	4	no connection

3.3 General-Purpose Power Cable (403-0-0065)

The General-Purpose power cable is 2 meters (6.56 feet) long, when connected to the Radian IS to SAE power cable, and has an SAE to two spring clip ends. This cable incorporates a 5-amp fast-blow fuse. It must be used with 403-0-0076, which is described in Section 3.4, *Radian IS to SAE Power Cable (403-0-0076)*, Page 12.

Use this power cable to connect a power supply (For example, a car battery) to the PWR port on your Radian IS receiver.

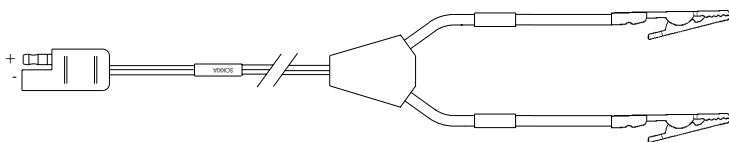

Figure 4: SAE to Battery Spring Clips Power Cable Section - Illustration

Table 2: General-Purpose Power Cable - Spring Clip Configuration

Spring Clip	
Pin	Description
+	Red Spring Clip
-	Black Spring Clip

Table 3: General Purpose Power Cable - SAE Configuration

SAE	
Pin	Description
+	Socket
-	Plug

3.4 Radian IS to SAE Power Cable (403-0-0076)

The Radian IS to SAE power cable is for use with the PDL base battery and other power cables that have an SAE connector (for example, the General Purpose Power Cable (403-0-0065) on *Page 11*).



Figure 5: Radian to SAE Power Cable Section - Illustration

Table 4: Radian to SAE Power Cable - Lemo Pin Configuration

Pin	Description	Color
1	Ground	Brown
2	Power	Orange
3	Not connected	Red
4	Not connected	Black

Table 5: Radian to SAE Power Cable - SAE Configuration

SAE	
Pin	Description
+	Plug
-	Socket

Section 4 Serial Communications

The following subsections provide technical information about the Radian IS communication ports and cable pinouts.

Serial cables are used to transfer data to and from the Radian IS receiver, and the Radian IS receiver transfers data through both of its communication ports. You will notice that the communication ports on the Radian IS are referred to as COM1 and COM2.

For more information on the Radian IS communication ports, please refer to your *Radian IS Operations Manual*.

As well, ready-made and tested cables are provided by Sokkia for use with your system. Please contact your Sokkia dealer for more information.

4.1 Communication Ports

The two communication ports (COM1 and COM2) on the Radian IS use LEMO EEG.IK.310.CLN sockets.

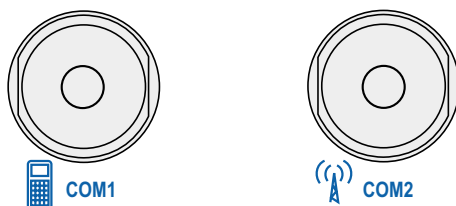

Figure 6: COM Port Close-Up

4.2 Radio Data Cable (403-0-0037)

The radio data cable is 2 meters (6.56 feet) long and has 10-pin LEMO to DB9 (female) connector ends. The radio data cable can be used in a base configuration to connect a radio to the COM2 port on the Radian IS receiver.

- ☒ **Note:** The radio data cable is not intended for use with the Pacific Crest radio. Use your Pacific Crest radio with its supplied Pacific Crest cable.

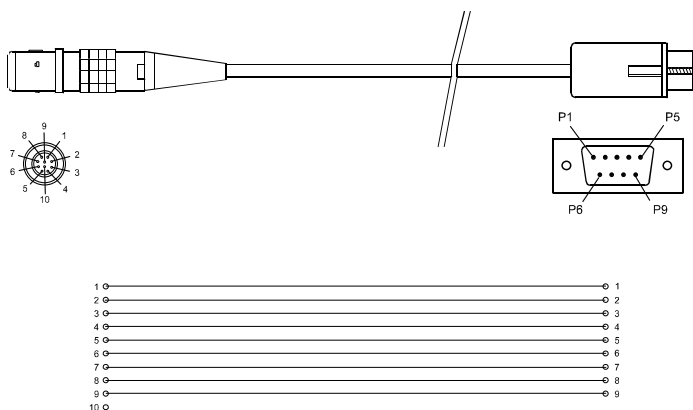

Figure 7: Radio Data Cable - Illustration

Table 6: Radio Data Cable - Pin Assignment

LEMO Pin	Description	Color	DE9P Pin
1	DCD	Brown	1
2	RXD	Black	2
3	TXD	Red	3
4	Ground	Orange	4
5	Ground	Yellow	5
6	DSR	Green	6
7	RTS	Blue	7
8	CTS	Violet	8
9	Battery	Grey	9
10		White (Not used)	

4.3 PC Data Cable (403-0-0036)

The PC data cable is 2 meters (6.56 feet) long and has 10-pin LEMO to DB9 (male) connector ends.

The PC data cable, when connected to the COM1 port of the Radian IS receiver, can be used in a Radian IS system base or rover configuration to allow data communication between the receiver and a PC.

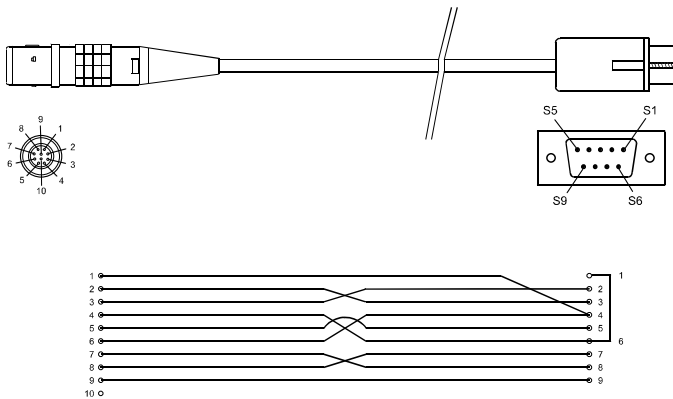

Figure 8: PC Data Cable - Illustration

Table 7: PC Data Cable - Pin Assignment

LEMO Pin	Description	Color	DE9S Pin
1	DCD	Brown	4
2	RXD	Black	3
3	TXD	Red	2
4	Ground	Orange	6
5	Ground	Yellow	5
6	DSR	Green	4
7	RTS	Blue	8
8	CTS	Violet	7
9	Battery	Grey	9
10		White (Not used)	1 jumpered to 6

4.4 SDR33 Data/Power Cable (403-0-0035)

The SDR33 data/power cable is 2 meters (6.56 feet) long and has SDR 6-pin Fischer connector to 10-pin LEMO connector ends.

The SDR33 cable is used in a Radian IS system rover configuration to connect the SDR data collector to the COM1 port on the Radian IS receiver.

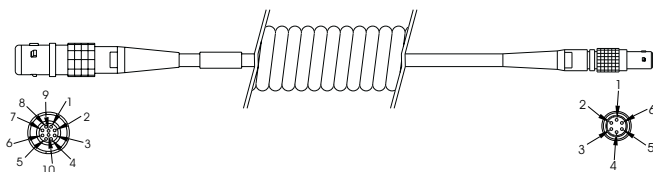

Figure 9: SDR33 Data/Power Cable - Illustration

Table 8: SDR33 Data/Power Cable - Pin Configuration

LEMO Pin	Description	Fischer Pin	Description
1	no connection	no connection	-
2	RXD	2	TXD (COMMS <-->)
3	TXD	3	RXD (COMMS -->)
4	no connection	no connection	-
5	Ground	1	Ground
6	no connection	no connection	-
7	RTS	4	DCD
8	CTS	4	DCD
9	Power	6	Power In
10	no connection	no connection	-

4.5 GPS Receiver/DAP Cable (403-0-0061 coiled; 403-0-0082 straight)

The GPS Receiver/DAP Cable is 1.5 meters long (59 inches). Both the coiled and the straight (*Figure 10*) variations of this cable have a LEMO 10-pin connector to 7-pin Fischer connector ends. They also have the same pin configurations as seen in *Table 9*.

This cable is used in a Radian IS system rover configuration to connect the DAP data collector to the COM1 port on the Radian IS receiver.



Figure 10: GPS Receiver/DAP Straight Cable - Illustration

Table 9: GPS Receiver/DAP Straight /Coiled Cable - Pin Configuration

LEMO Pin	Description	Fischer Pin	Description
no connection	-	1	+ 5 VDC input
no connection	-	2	Charge power output
1	DCD	no connection	-
2	RXD	3	TXD
3	TXD	4	RXD
4	Ground	no connection	-
5	Ground	7	Ground
no connection	-	6	DTR
6	DSR	no connection	-
7	RTS	no connection	-
8	CTS	no connection	-
9	+12 VDC input	no connection	-
10	no connection	no connection	-

4.6 Rover PDL Radio Cable (403-0-0069; 403-0-0091 and 403-0-0043 variations)

The Rover PDL Radio cable is 548 mm long (23 inches) and has a LEMO 10-pin connector to LEMO 5-pin connector ends.

This cable is used to connect the Radian IS Rover Radio to the Radian IS, Radian, or Novatel DL rover.

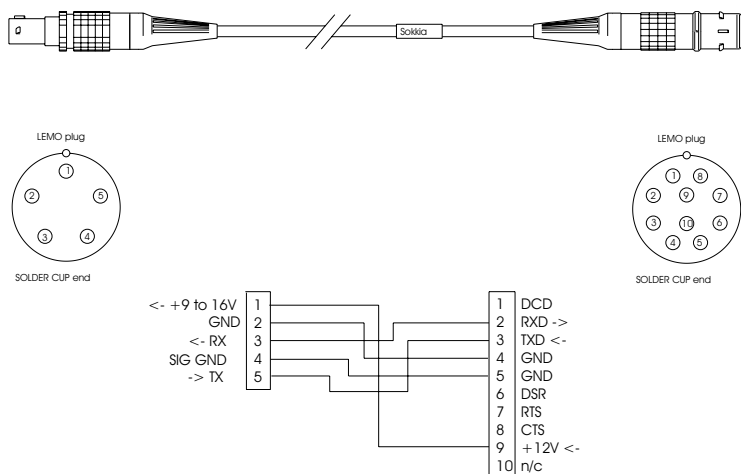
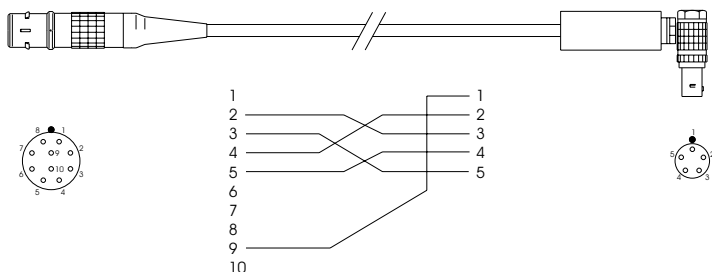

Figure 11: Radian IS Radio/Rover Straight Cable - (403-0-0069) Illustration

Table 10: Radian IS Radio/Rover - Pin Configuration

Fischer Pin	Description	LEMO Pin	Description
1	+9 to +16 V	9	+12 V
2	Ground	4	Ground
3	RX	2	RXD
4	Signal Ground	5	Ground
5	TX	3	TXD
no connection	-	1	DCD
no connection	-	6	DSR
no connection	-	7	RTS
no connection	-	8	CTS
no connection	-	10	no connection

There are two other variations of this cable for the Radian or Radian IS. One is 23" (548 mm) long with right-angled connections (403-0091 - not shown) and the other is 60" (1.524 m) long with a right-angled connection on the PDL end and a straight connection on the Radian IS end (403-0-0043 - as seen in *Figure 12*).

**Figure 12: Radian IS Radio/Rover Right Angle Cable - (403-0-0043) Illustration**

4.7 Base PDL Radio Cable (403-0-0062)

The Base PDL Radio cable is 5.99 m long (236 inches) and has a Fischer 5-pin connector to SAE connector and 10-pin LEMO connector ends.

This cable is used to connect the Radian IS Base PDL Radio and SAE connector to receivers including the Radian IS, Radian, or Novatel DL base.

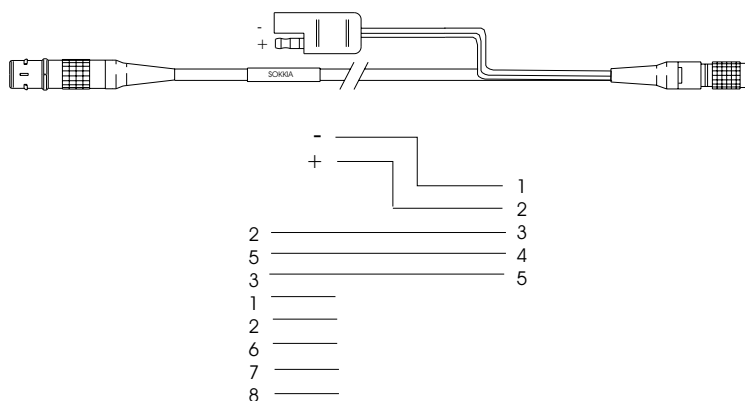

Figure 13: Radian IS Radio/Base/SAE Cable - Illustration

Table 11: Radian IS Radio/Base/SAE - Pin Configuration

Fischer Pin	Description	SAE Pin	Description	LEMO Pin	Description
1	+9 to +16 V	+	Plug	no connection	-
2	Ground	-	Socket	no connection	-
3	TXD	no connection	-	2	RX
4	Signal Ground	no connection	-	5	Ground
5	RXD	no connection	-	3	TX
no connection	-	no connection	-	1	RTS
no connection	-	no connection	-	2	CTS
no connection	-	no connection	-	6	-
no connection	-	no connection	-	7	-
no connection	-	no connection	-	8	+12V

Index

A

AC/DC converter 4

B

base 14–15, 20

baud 6

C

cable

- communication 7–8, 13

- insertion 3

- power 5, 11

- removing 3

- serial data 7

COM1 6, 8, 13, 15–16

COM2 6, 8, 13–14

communication port, see serial port

D

DAP 17

E

external power source 4, 9

F

fuse 11

I

insert a cable 3

internal batteries 4, 9

P

PC data 15

power

- cables 5, 11

- interruptions 4

- port 2, 9

R

radio 14, 18–20

rover 15–19

RS232 6

S

SDR 6, 16

serial port 2, 6, 8, 13, 15

SLA 10

spring clip 11

T

transfer data 13

V

voltage 4–5

W

warning, voltage 4